

High Discharge Feed Hopper

A PRODUCT OF THE MATERIAL HANDLING EQUIPMENT FAMILY

Peerless offers heavy duty belt feeders for the mining, aggregate and construction industries. From standard pre-engineered to one-of-a-kind solutions, we have the experience to solve your unique needs.

Material handling equipment with feed hoppers attached to the tail of a conveyor is typically used for loading trucks or plants. The high discharge feed hopper is a reliable method for conveying materials up to 3" top size or smaller. It's capable of up to 400TPH.

Screen materials

- Rock
- Sand and gravel
- Coal
- Clinker or raw materials at a cement plant
- Truck loading
- Plant loading
- Rail car loading
- Granular soils
- Other non-compacting bulk materials

Benefits

- Rugged, portable design
- Wide target
- Mechanical gate control
- Well-suited for materials less than 3"



12' x 7' 13 cubic yard (struck capacity) portable high discharge feed hopper

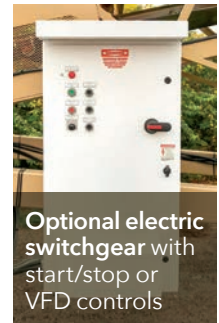

Optional electric switchgear with start/stop or VFD controls



Optional hydraulic power packs with motor, reservoir, pump, valves and hoses



Cut off gates and variable speed drives to mechanically manage material flow



Portable running gear with Pintle hitch connection



Custom Solutions to Unique Challenges

HIGH DISCHARGE FEED HOPPER

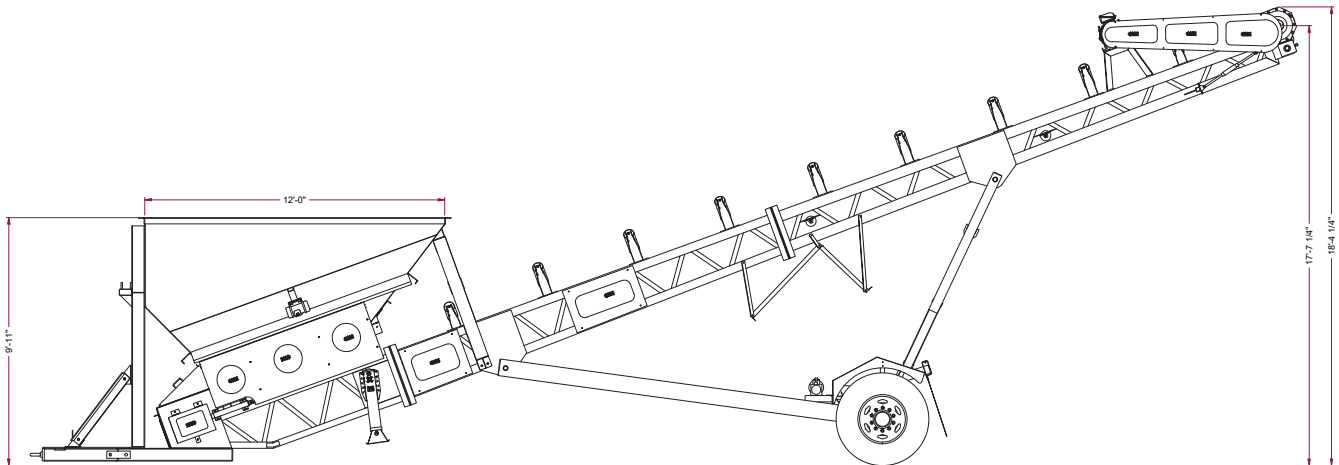

Standard Specifications

- 1/4" steel 12' x 7' hopper with 13 cubic yards / 18 ton capacity
- 36" wide x 45' long belt feeder conveyor with a discharge height of 17'-7"
- Up to 400 TPH capacity
- 20HP, 1800 RPM 3 phase electric motor with a Dodge torque arm reducer
- 16" diameter, 3/8" herringbone rubber lagged head pulley and 14" diameter wing type tail pulley
- 1045 shafts turned and polished
- Dodge SCM pillow block bearings
- Manual screw type belt take-ups
- 3 ply 3/16" x 1/16" conveyor belt with Flexco belt splice
- CEMA C 5" diameter idlers on 5' spacings
- Heavy duty truss type frame

- Estimated weight 15,838 lbs.
- Complete feed hopper is primed and painted Peerless Tan

Optional Equipment

- Hopper extensions
- Manual grizzly
- Hydraulic operated grizzly
- Electrical switchgear with fixed speed drives or variable frequency drives (VFD)

Contact us at (913) 233-3854 or sales@peerlessemc.com to get started.



ABOUT PEERLESS

Peerless solves unique challenges for our customers by supplying material processing and handling equipment—including quarry, asphalt, aggregate, frac sand, and mining. Peerless designs a variety of stock and custom products, ensuring consistent delivery of engineered solutions. Experienced and innovative, the Peerless team is focused on quality and listening to customers' specific needs.

© 2019 Peerless Engineering and Manufacturing Co.

www.peerlessemc.com

Kansas City office (913) 233-3854
Request a quote (816) 381-0635
sales@peerlessemc.com

 Peerless Engineering and Manufacturing Company